

Health Risk Assessment of Occupational Exposure to a Magnetic Field From Magnetic Resonance Imaging Devices

Jolanta Karpowicz
Krzysztof Gryz

Central Institute for Labour Protection – National Research Institute, Poland

Health care staff who operate magnetic resonance imaging (MRI) devices are exposed to a static magnetic field of significant spatial heterogeneity always produced by MRI magnets during the whole shift. They can also be exposed to pulses of a time-varying magnetic field (gradient field) present only during patients' examinations. The level of the workers' exposure depends both on the type of the magnet and on the ergonomic design of each MRI device.

The paper presents methods used for measuring and assessing workers' exposure. It also discusses the results of inspection measurements carried out next to approximately 20 MRI devices of approximately 0.2–2.0 T. The presented characteristic and overview of the variability of workers' exposure to a variety of MRI devices supports the need for data on monitoring occupational exposure to MRI. International exposure assessment standards and guidelines (International Commission on Non-Ionizing Radiation Protection [ICNIRP], Institute of Electrical and Electronics Engineers [IEEE], American Conference of Governmental and Industrial Hygienists [ACGIH], European Commission directive), and those established in Poland are also compared.

MRI occupational exposure electromagnetic fields exposure assessment

1. INTRODUCTION

Nuclear magnetic resonance (NMR) is a well known research method involving the phenomenon of resonant absorption and re-emission of radiofrequency (RF) radiation by protons in a strong static magnetic field. It can be used for medical imaging or spectral analysis of the chemical structure of samples. In magnetic resonance imaging (MRI) systems used for medical examinations, a required magnetic field is the result of summation of two components: a static field constantly produced by strong magnets (permanent, resistive or superconductive) and pulses of a time-varying gradient field produced by gradient coils located inside the housing of an MRI scanner [1]. Diagnostic coils placed on an MRI table or

directly on the body of a patient produce pulses of RF radiation. The dynamic changes in the spatial distribution of a static magnetic field resulting from the summation of its static and time-varying components, enable three-dimensional changes in a resonating absorption of RF by a patient's tissues and, as a result, three-dimensional imaging of the internal structure of the body.

Magnets are used as a source of this strong static magnetic field. Usually these are superconductive or permanent magnets, in which a static magnetic field is constantly generated. Resistive magnets can be switched off when a shift is over. The subject (a selected part of the patient's body) lies on an MRI table located within the patient imaging area, i.e., in the area of the homogeneous static magnetic field in the bore of the magnet's housing (in the case of a

Investigations have been supported by the State Committee for Scientific Research of Poland and Poland's Ministry of Economy, Labour and Social Policy (grant I-3.10), and the TEST-PRO-SAFETY-LIFE Centre (European Commission Fifth Framework Programme GMA1-2002-72090).

Correspondence and requests for offprints should be sent to Jolanta Karpowicz, Central Institute for Labour Protection – National Research Institute, Laboratory of Electromagnetic Hazards, Czerniakowska 16, 00-701 Warszawa, Poland. E-mail: <jokar@ciop.pl>.

closed MRI device) or in the open space between magnet's legs (in the case of an open MRI device). The magnet is situated in an MRI room, which is usually electromagnetically shielded to screen the scanner from all kinds of outside electromagnetic radiation. RF radiation and gradient magnetic fields are generated in sequences of pulses.

For health care staff (nurses, technicians and radiologists), the static magnetic field from MRI scanners is of special concern as during the shift the field is always turned on. Highest exposure occurs in the direct proximity to the magnet's housing. Health care workers are exposed to static magnetic fields while attending patients before and after examination and also while operating the scanner's console situated on the housing of the magnet. Exposure to gradient and RF pulses is possible only during an examination; it affects workers in special cases only, e.g., during so-called dynamic examinations or in emergencies. During examinations, attendants usually remain outside the MRI room, in front of the computer that controls the examination. The new technique for interventional medical procedures is an exception, with medical staff assisting in examining patients. This kind of exposure is not considered in this paper; neither is exposure of technicians involved in repairing or adjusting scanners.

In Poland there are regulations [2, 3] defining the principles of assessing exposure to electromagnetic fields (EMF) of workers and of the general population. They introduce the obligation to carry out periodic testing of EMF in the working environment. Polish standards [4, 15] determine requirements regarding measuring devices used for examining the working environment and protocols how to measure EMF and assess workers' exposure. Since the first regulations concerning permissible occupational exposure to a static magnetic field published in Poland in 1995, a series of inspection measurements have been carried out to examine working conditions during the operation of MRI devices. This paper presents measurement methods used for investigating static and gradient magnetic fields, a review of the principles and results of assessing workers' exposure and the results of exposure assessment. The rules of exposure assessment used in Poland

are also compared with the recommendations of the International Commission on Non-Ionizing Radiation Protection (ICNIRP) [5], the Institute of Electrical and Electronics Engineers (IEEE) [6], the American Conference Governmental and Industrial Hygienists (ACGIH) [7] and the European Commission (EC) [8] regarding assessment of occupational exposure.

2. PERMISSIBLE OCCUPATIONAL EMF EXPOSURE

2.1. Static Magnetic Fields

Magnets of magnetic flux density from the range 0.2–3.0 T are currently used for MRI scanners. Static magnetic fields from patients' examination areas are of very high relative homogeneity of the order of 10 ppm (10×10^{-6}). By contrast, the spatial distribution of the field in the vicinity of the magnet's housing, where workers' activities take place, is of relatively high heterogeneity. The level of the field is typically 100-fold lower at a distance of 2 m from the cover of the magnet's housing than on the cover.

Hall voltages or Lorentz forces are the physical effects of static magnetic fields on electrical charges inside an exposed body. The IEEE standard [6] summarises the effects of exposure to static magnetic fields. Observable effects can result at first from a rapid movement of the body or eyes within a strong static field, which is of special concern to workers. The adverse effects noted at 1.5 T exposure include vertigo, difficulty with balance, nausea, headaches, numbness and tingling, phosphenes, and unusual taste sensations. There are more reactions in higher fields. Other direct effects of exposure to static magnetic field can result from magnetohydrodynamic forces on moving charges within a magnetic field. Following data in the IEEE standard, such movement, is typically associated with the vascular system, and can cause, e.g., a 0.2–3.0% change in blood velocity in the case of exposure to 1–10 T and should be considered in a discussion a patient's safety. For workers, the limitation preventing

adverse effects associated with rapid movements within an exposed area is more restrictive.

The results of static magnetic field measurements were evaluated on the basis of criteria given in the occupational safety and health regulation [2]. According to these regulations, exposure limitation consists of three levels of workers' protection against excessive exposure: (a) a ceiling value of prohibited exposure, separate for whole-body and for limb exposure; (b) a range of exposure level associated with exposure assessment considering exposure level and exposure duration, with the use of an exposure factor; (c) a threshold between occupational and non-occupational exposure.

Workers should not access an area in which the flux density of a static magnetic field is higher than 100 mT (level [a] of whole-body exposure). Permissible duration of exposure to a field of 10–100 mT (range [b] of whole-body exposure) is defined by the exposure factor ($W < 1$). According to this regulation [2] and the relevant Polish standard [4], occupational exposure of each individual worker is evaluated by the sum of the worker's doses calculated at a so-called moving work place (i.e., activities are performing in various places within fields of various levels) in order to determine the exposure factor expressed by Equation 1:

$$W = \frac{\sum B_n^2 \cdot t_n}{800 \text{ mT}^2 \text{ hr}}, \quad [1]$$

where W —exposure factor of an individual worker, B_n —flux density in the place where a particular working activity can be assumed to be stationary (in a fixed place), t_n —duration of this activity, 800 mT²hr—permissible dose for whole-body exposure (calculated as a square of 8-hr permissible exposure of 10 mT multiplied by 8 hrs).

According to the same regulation [2], the ceiling value for limb exposure is fivefold higher than that of the whole body. Limbs (hands of medical staff) can be exposed to fields of up to 500 mT for a limited time of exposure, if the exposure factor calculated by a modified Equation 1 (with a permissible dose of 20,000 mT²hr) is not greater than 1.

The formula for calculating a dose by multiplying the squared field strength or magnetic flux density by duration of exposure to such a field was introduced into the occupational regulation established in Poland for the 0 Hz–300 GHz frequency range [2]. Because of insufficient scientific data for differentiating the formula for dose calculations for EMF of various frequencies, a uniform formula for both low and high frequencies was adopted. This was verified during the long years of legal implementation as the most effective for occupational safety and health practice carried out in enterprises by employers. Its main function is to prevent long daily exposure of workers to high-level EMF as an implementation of precautionary practice in the working environment.

The area of magnetic fields of occupational exposure (above threshold [c]) should be identified and marked with warning signs and closed for workers who are not informed about the hazard and whose health has not been examined in relation to occupational exposure to EMF. In the case of static magnetic fields, the threshold of occupational exposure was established at 3.3 mT (as the value threefold lower than the 8-hr permissible exposure level). Separate occupational regulations define permissible exposure of young workers (under 18) and pregnant women. These groups should not be occupationally exposed, irrespectively of the duration of exposure. The permissible exposure of the general public was harmonised with the occupational exposure threshold and established in a separate environmental regulation [3] at the level of 3 mT.

Various international recommendations for occupational exposure assessment [5, 6, 7, 8] and regulations established in Poland [2] are compared in Table 1. Following this international guidance, in addition to workers' exposure limitations, safety levels for hazards caused by "flying metallic objects" (3 mT) and possible wiping out of magnetic memories/cards and implanted cardiac pacemakers (0.5 mT) should also be taken into consideration, e.g., by labelling areas in which such hazards are present.

TABLE 1. Permissible Occupational Exposure to a Static Magnetic Field

Recommendations	Whole Body		Limbs		Cardiac Stimulators and Implanted Electronically Activated Devices
	Whole Working Day	Ceiling Value	Whole Working Day	Ceiling Value	
ICNIRP guidelines [5]	200 mT	2 T	not fixed	5 T	0.5 mT
EC directive [8]	200 mT	not fixed	not fixed	not fixed	mentioned but not fixed
IEEE standard [6]	500 mT	500 mT	500 mT	500 mT	mentioned but not fixed
ACGIH [7]	60 mT	2 T	600 mT	5 T	0.5 mT
Polish regulations [2]	10 mT	100 mT	50 mT	500 mT	not mentioned

Notes. ICNIRP—International Commission on Non-Ionizing Radiation Protection, EC—European Commission, IEEE—Institute of Electrical and Electronics Engineers, ACGIH—American Conference of Governmental and Industrial Hygienists.

2.2. Gradient Magnetic Fields

Sequences of pulses of a magnetic gradient field and RF radiation (8–120 MHz) are generated in order to enable three-dimensional discrimination of the examined tissue. In the area where patients are present during examinations, the time derivatives of gradient field amplitude changing in time (dB/dt) are typically of 1–3 T/s rate of rise/fall. Figure 1 shows an example of time-variability of gradient magnetic field amplitude from a 2.0 T scanner.

Health care staff are not exposed to a gradient field near a magnet, except for some types of examination or during examination of patients with special needs (e.g., children), when a worker's presence close to an MRI device during gradient field emission might be necessary. When these investigations were carried out, there were no established international recommendations for permissible exposure of workers to gradient

fields. The assessment criteria for this component of exposure were compiled at the Central Institute for Labour Protection – National Research Institute (CIOP-PIB). They were based on the available data on the direct effects of exposure.

International Standard No. IEC-601-2-33:1995 [9] has established the level of a gradient magnetic field dB/dt < 20 T/s, for pulses longer than 0.12 ms, as safe for patients undergoing MRI examination (normal operating mode of an MRI scanner). This limitation was established to prevent acute reactions in the body of a patient lying on an MRI table. The International Electrotechnical Commission (IEC) has not established criteria for occupational exposure. However, data concerning the thresholds of acute effects of exposure considered by IEC in establishing exposure limitation for patients were taken as highly recommended by experts and used for formulation in Poland in 1998 the exposure

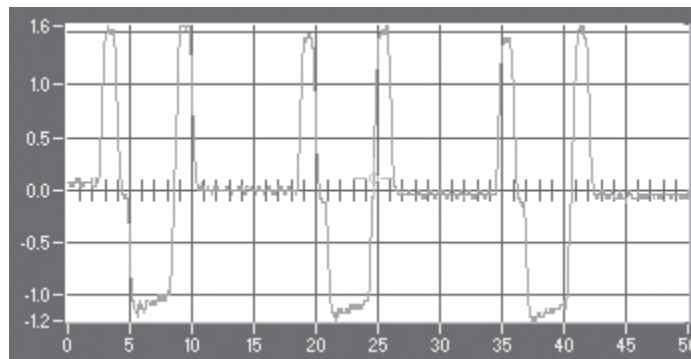

Figure 1. An example of the time-variability of magnetic gradient field pulses (registration of the current supplying a gradient coil): 5 ms/div, 0.5 V/div.

limitation for workers. The following assumptions were taken when developing this proposal for the assessment of occupational exposure to gradient fields: limitation of occupational exposure should prevent direct nerve excitation and also any other reaction caused by induced current in the worker's body. Thresholds for particular reactions in exposed body experimentally established by different investigators and for various reaction (e.g., for nerve or muscle excitation) differ more than tenfold for the same frequency of affecting fields. It should be also taken into consideration that workers have to move, even rapidly, while attending patient in the area exposed to EMF and workers exposure is repeated, even manifold during the shift. Taking these facts into the consideration, a reduction factor of 50 was used in relation to the IEC accepted patients' safety level (20 T/s [10, 11]) and permissible occupational level was fixed at 0.4 T/s. The level of such established protection was assessed also by the analysis of induced currents associated with the exposure to gradient fields of 0.4 T/s. Density of induced current calculated for the fields of 60 T/s within the cylindrical model of the human body is 1.2 A/m^2 [11]. This level refers to the threshold of nerve excitation. In the same model, the density of induced current calculated for 0.4 T/s is about 8 mA/m^2 . This current is lower than 10 mA/m^2 and does not cause noticeable effects in an exposed body [12]. This analysis was taken as confirmation for the gradient field's limitation taken for presented investigations. The measurements method recommended by IEC for gradient fields assessment used for investigations is described in section 3.

The proposal of the similar level for permissible occupational exposure (0.22 T/s for the components of the frequencies lower than 820 Hz, and above the values proportional to the frequencies) was published in 2000 [13] and approved for ICNIRP's 2003 guidance on pulsed fields [14]. The analysis carried out for ICNIRP guidelines was based on the protection against exposure to gradient fields which induce the currents of density higher than 10 mA/m^2 . The use of the measurement devices with an appropriate low-pass filter that measures and processes dB/dt simultaneously for each of three

orthogonal coils was recommended by ICNIRP's guidance [14]. This method of measurements is different than recommended for gradient fields by IEC [9] but the levels of worker's protection according to both approaches, worked out in Poland and from ICNIRP guidance, seems to be similar in the case of gradient fields from MRI devices.

3. MEASUREMENTS METHODS AND UNCERTAINTY OF EXPOSURE ASSESSMENT

The measurements of occupational exposure to static magnetic fields were carried out with the use of a magnetic flux density meter with a Hall sensor, and in accordance with methodology as shown in Polish standards [4, 15]. Basic principles of the static magnetic field's measurements methodology used for presented investigations are as follow:

- considered exposure component: magnetic flux density, B (mT),
- measurement devices: isotropic Hall probe (3 orthogonal components of a vector),
- measurement protocol: spot measurements of maximum value of exposure level referring to worker's body location, for the whole body (head, trunk) and hands separately.

The exposure duration was also taken into consideration because exposure limitation concerning whole working day's time-averaged exposure level as well as ceiling value are defined separately.

For the measurement of the gradient fields in the working environment, a special measuring set consisting of a loop antenna, compatible with IEC-601-2-33:1995 [9] and a digital oscilloscope has been prepared and calibrated in the CIOP-PIB laboratory of reference electromagnetic fields. The magnitude of the component of dB/dt coaxial with the antenna can be determined from the peak voltage induced in the antenna (Figure 2). The voltage induced in the antenna is proportional to the time-derivative of incident field. In consequence, the dB/dt fields of linear rise/fall changes are converted into induced flat-level

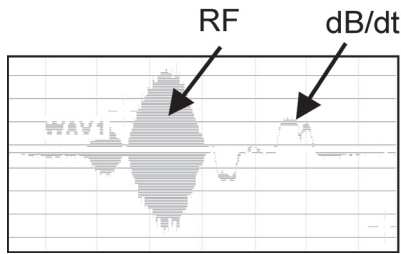

Figure 2. An example of a gradient magnetic field dB/dt registration: 1.0 ms/div, 2.0 mV/div.

voltages. The voltage induced in the antenna by the sinusoidal magnetic field is also sinusoidal, with the phase-shift and amplitude proportional to the frequency of this field. For this method of gradient field's assessment, the measuring frequency range of the measuring set (the flat response's frequency range) should at least cover the range of the frequency spectrum of the measured signal.

The basic principles of the used measurements methodology are summarised in Table 2.

The basic calibration's uncertainty of Hall probe flux meters is of the order of 1–2%. But the uncertainty of workers' periodic exposure assessment is significantly higher. The main components of it are variability of exposure pattern, the uncertainty of measurements and their

repeatability. The worker's activities (duration and location of them in respect to the housing of the magnet) are varying from one patient's examination to other because of examination of various parts of the body and additionally various needs of particular patients. In consequence the exposure level as well as duration are varying from one to next examination, and from one shift to other. The results of measurements of worker's exposure level and exposure assessment executed for any of the examples of patient's attending work scenarios, as well as for the typical or the worst case one have only limited representation of real situation. The repeatability of measurements for assessment of the exposure in the workplace is also of much higher uncertainty than magnetic flux density meter's calibration when is carried out by various investigators. The main reason for it is extremely high spatial heterogeneity of exposure level in the area of worker's activities. The evaluation of effects of these uncertainties for the assessment of worker's exposure to static fields were consider within the international comparative tests carried out by CIOP-PIB (Poland), VITO (Belgium) and ISPEL (Italy) institutes within the activities of the TEST-PRO-SAFETY-LIFE Centre [16].

TABLE 2. Measurement Methodology Used in Presented MRI Investigations

EMF Exposure Component, Quantity, Unit	Measurement Devices	Measurement Protocol	Exposure Assessment
static magnetic fields, B , mT	<ul style="list-style-type: none"> • Hall probe • isotropic sensor (vector with 3 orthogonal components) 	<ul style="list-style-type: none"> • spot measurements of the maximum exposure in selected places corresponding to a worker's body locations • measurements regarding <ul style="list-style-type: none"> • whole body (head, trunk) • hands 	estimation of worker's exposure factor according to precise measurements of spatial distribution of B and rough estimation of the duration of exposure in selected places of various activities for attending patients
gradient magnetic fields, dB/dt , T/s	unshielded loop antenna for osciloscopic investigations	spot measurements where workers are active	estimation of the maximum value of dB/dt on the basis of the amplitude of a voltage plateau

Notes. MRI—magnetic resonance imaging. EMF—electromagnetic field, B —magnetic flux density, dB/dt —rate of rise/fall.

The exposure to static magnetic field in the vicinity of an MRI device was examined with the use of various magnetic flux meters by the two groups of researchers. The uncertainty and comparability of results obtained by two groups were assessed following the ISO/IEC guide [17]. According to the rules described by this guide, the comparison of measurements of the selected subject done by 2 laboratories are classified as positive when the value of mod (UO) are below 1:

$$\left| UO = \frac{B_1 - B_2}{\sqrt{u_1^2 + u_2^2}} \right| \leq 1, [2]$$

where B_1 and B_2 —results of measurements done in particular place by each laboratory, number 1 and 2; u_1 and u_2 —standard uncertainty of measurements done by each laboratory, number 1 and 2.

Following the rules from the ISO/IEC guide [17], results of measurements should be reported in the routine method use by each laboratory, and uncertainty should represent the total uncertainty of measurements covering all significant components, established by each laboratory with the use of statistical or analytical methods, described by the guide. For the presented comparison, each laboratory was reporting the measurement results by own responsibility. The measurements uncertainties were assumed as $u_1 = u_2$ for further analysis because both participating laboratories were taken as equivalent.

The first set of measurements was focused on the distribution of magnetic flux density in the horizontal axis of the magnet's bore at the front side of the magnet. The set of coincidental spot measurements, were carried out by the two groups of researchers. These measurements were carried out by both groups coincidentally, in particular points determined together in selected distances towards the magnet's housing. Following calculations, it was found that the minimum standard uncertainty of measurements, which should be taken to obtain the positive evaluation of comparison of results obtained by both laboratories, $|UO| < 1$, is $u_1 = u_2 = 6\%$.

The second set of measurements was focused on the assessment of workers exposure. The

series of consecutive spot measurements in the vicinity of magnet's housing where the medical staff is exposed while attending the examination of the patients, were carried out by each groups of researchers separately. Each group determined by own responsibility the locations for measurements representing workers exposure. Following calculations, it was found that the minimum standard uncertainty which should be taken for measurements done by both groups, to obtain the positive evaluation of comparison, are

- for location 1 (hand's exposure close to the magnet's housing): $u_1 = u_2 = 3\%$,
- for location 2 (whole body exposure, 0.35 m from the magnet's cover): $u_1 = u_2 = 23\%$.

In the case of the measurements carried out in locations relatively well determined (hand's exposure or coincidental measurements), the results obtained from both groups shown very good agreement. In the case of measurements carried out in area of field of significant heterogeneity and carried out in locations not strictly determined, the obtained results shown that uncertainty of real worker's exposure assessment should be taken as much higher than magnetic flux meter calibration's uncertainty, even of the order of 20–50%. It should be considered while analysis the possible preventive measures for practical protection of workers against excessive exposure to electromagnetic fields from MRI devices.

4. RESULTS OF EXPOSURE MEASUREMENTS AND ASSESSMENT

Presented results concern 20 various types of MRI devices of 0.2, 0.23, 0.3, 0.38, 0.5, 1.0, 1.5 and 2.0 T magnets. Investigated MRI units are use for medical examination of various tissues, but head's examinations were the most frequently carried out.

4.1. Worker's Activities Characteristic

In the case of investigated MRI devices, the attending to one patient before/after examination, usually making in a few different locations inside

the MRI room at the distance of 0.3–1.5 m from the housing of the magnet, in the most of observed cases lasted of 2–15 min. The basic activities are as follow (Figure 3):

- attending while patient's access and lay down on the MRI table (areas A + B),
- positioning of diagnostic's RF coils on the MRI table or patient's body (areas A + B),
- plugging in/unplugging the RF coils' cables into the supplying socket (areas A + B or D or E),
- MRI table positioning for fixing its initial geometrical position and put in/out it into/from the area of uniform field (inside the magnet's bore or within open space of open device) (areas A + C),
- attending while patient is getting off from the MRI table (areas A + B).

In the case of certain types of examination, a patient is dosed with some pharmaceutical components, e.g., contrast, frequently when patient is placed inside the magnet. In the most of cases dosing/injection is made by nurses, even if the use of infusion pumps is technically possible. These activities last 1–2 min and is frequently the reason of high exposure of stuff within area D in Figure 3.

During patient's examination, the attendants usually are outside the MRI room, in front of the computer controlling the examination (area F, Figure 3).

Occasionally workers' exposure can be caused also by emergency situations which need urgent action, even inside the bore of the magnet, because of patient's health problems or technical reason.

Cleaners can be also exposed to high level of static magnetic fields inside MRI room or inside the bore of the magnet because permanent and superconductive magnets are permanently on.

4.2. Occupational Exposure to Static Magnetic Fields

The results of measurements of the magnetic flux density of static magnetic fields produced by various types of MRI devices 0.2–2.0 T (Figures 4 and 5) have shown that in each of the cases, the area of controlled access for persons with cardiac pacemakers ($B > 0.5$ mT) exist, up to the distance no longer than approximately 5 m from magnet. Defined by Polish regulations, occupational exposure's area ($B = 3.3$ –500 mT) can be found in a distance up to approximately 1.5–2.5 m from the magnet. In the case of

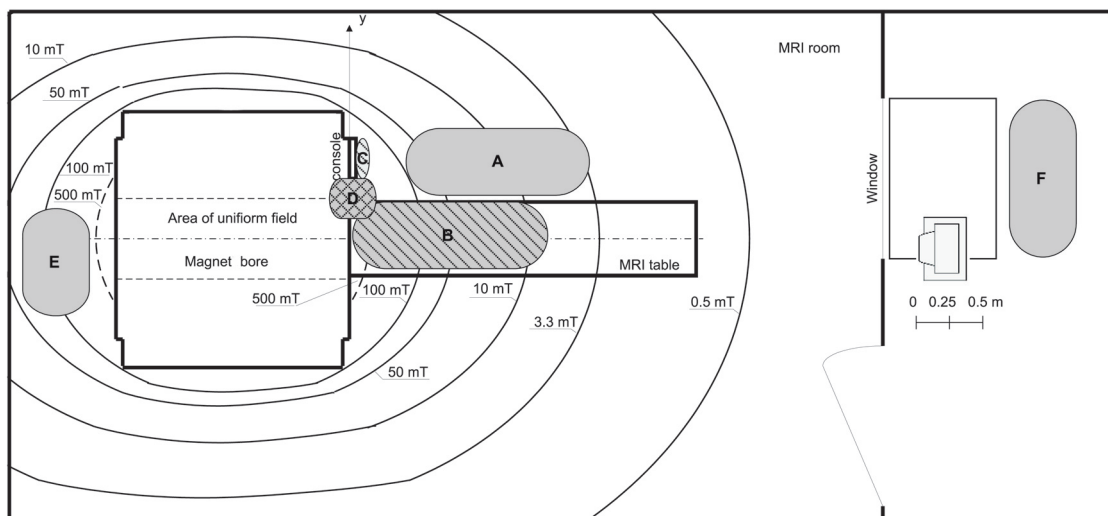

Figure 3. Exposure of health care staff when attending an MRI examination: area A, E, F—whole-body exposure; area B—exposure of hand or head if the worker is leaning towards the patient; C—hand exposure; D—hand or whole-body exposure when the worker approaches very closely the area of a uniform field (or leans against magnet housing). Notes. MRI—magnetic resonance imaging.

0.5–2 T MRI scanners, the area of the relatively high field, where occupational exposure limitations should be considered ($B > 100$ mT) can be found up to approximately 0.5 m from the border of the magnet’s bore. The spatial distribution of the field levels is significantly non-isotropic around the bore magnets’ housings: in front of and behind them much wider than sidelong. In the case of open MRI devices, the spatial distribution of the field is isotropic around the magnet’s housing.

Inside MRI rooms, the maximum exposure level in front of the magnet can reach 1000 mT (1.0 T). Exposure level in the area of workers’ routine activities can reach 150 mT (for whole body exposure) and 600 mT (for hands exposure)

(Table 3). In the case of performing professional activities very close or inside the magnet bore, workers can be exposed to higher fields. Exposure of hands to a static magnetic field up to 1500 mT (1.5 T) was found.

Exposure of workers outside the MRI room is lower, at a distance of 5–10 m, the magnetic field is normally less than 0.5 mT.

Measurement results have shown that the exposure factor W can exceed permissible value of 1, as well as permissible exposure levels (fixed by Polish regulations, or presented international guidelines) can be exceeded when activities of health care workers close to magnet is required while attending patients before/after examination.

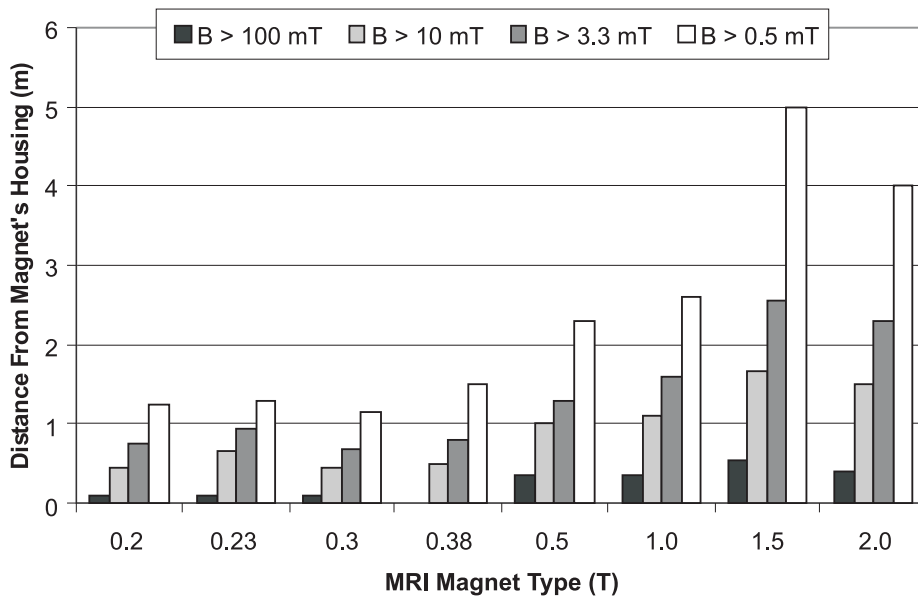

Figure 4. Spatial distribution of static magnetic fields in the vicinity of various types of MRI devices. Notes. MRI—magnetic resonance imaging.

TABLE 3. Static Magnetic Fields in Selected Places of the Most Typical Activities of Health Care Staff Attending Patients Before and After MRI Examinations

Activities	Health Care Staff Exposure Level (mT)		
	0.2 T open MRI scanner	0.5 T bore MRI scanner	1.5 T bore MRI scanner
Diagnostic RF coils positioning on an MRI table or the patient’s body—whole-body exposure	3–50	5–100	50–150
Diagnostic RF coils positioning on an MRI table or the patient’s body—hand exposure	5–100	20–250	100–600
Plugging in/unplugging RF coil cables into the supplying socket and console use—hand exposure	60–100	30–40	20–500 up to 1500*
Leaning against magnet’s housing maximum field on the accessible for workers cover of the magnet	200–270	80–300	250–600

Notes. MRI—magnetic resonance imaging, RF—radiofrequency. *—if the supplying socket is located inside a magnet bore.

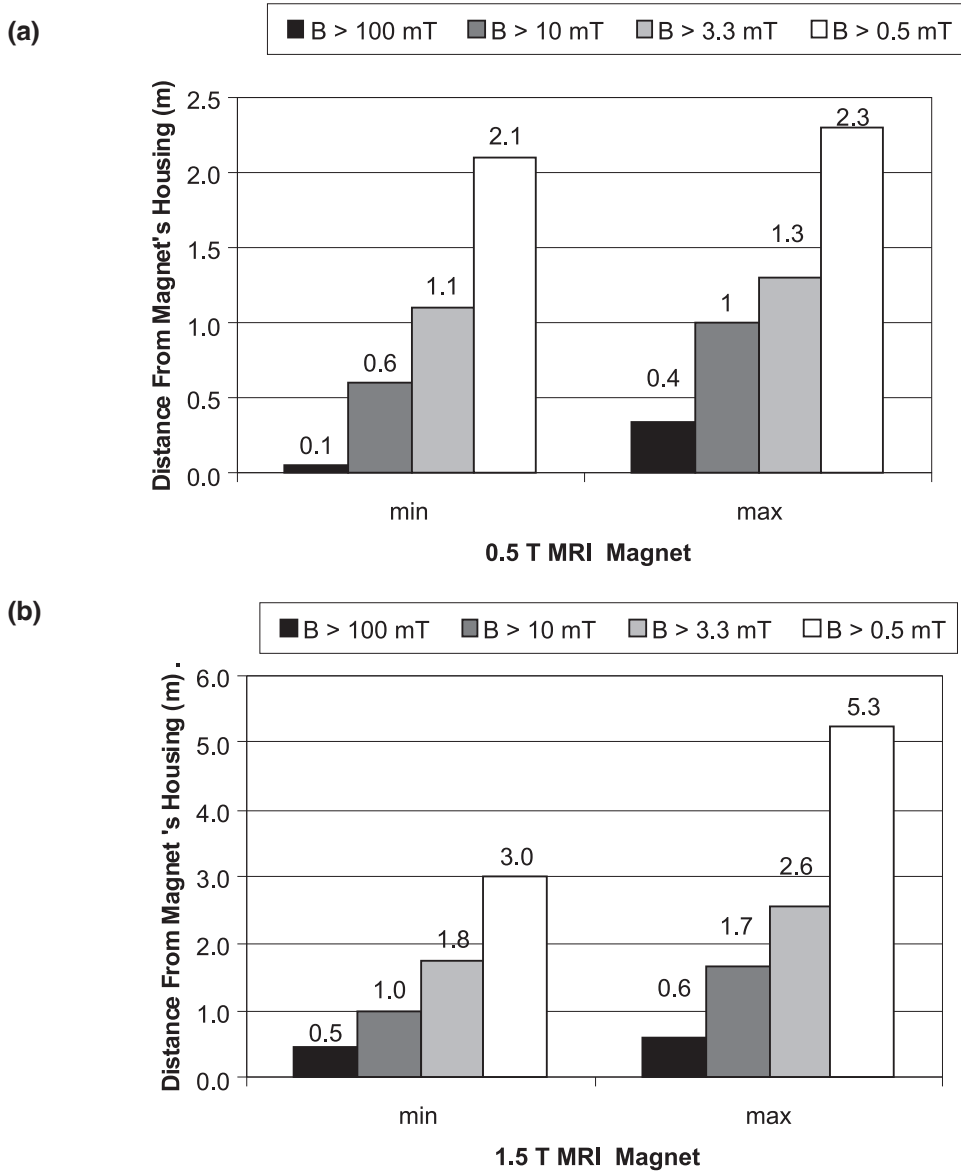

Figure 5. Spatial distribution of static magnetic fields in the vicinity of various MRI magnets: (a) 0.5 T, (b) 1.5 T. Notes. MRI—magnetic resonance imaging.

4.3. Gradient Magnetic Fields Exposure

The gradient fields were measured by the IEC-recommended measuring set described in chapter 3. The measuring set was calibrated in reference magnetic field source. In was established that its sensitivity is $\text{dB/dT} = 32 \cdot U$ (where dB/dt —time devirative of measured field, in T/s, U —peak voltage observed on the oscilloscope, in volts). Its was also found that frequency respond of this measuring set is frequency-proportional (linear) in the frequency range from 20 Hz up to 1 MHz.

The gradient pulses were of the duration of 0.5–1.5 ms, and of the sequences' repetition time of the order of a few tens of milliseconds (no less that 10 ms). Frequency components from the approximately 500 Hz up to about 35 kHz were found in the spectrum obtained from the registration of gradient pulses waves and the spectrum analysis (FFT).

The obtained results indicated that a gradient magnetic field, that can reach the level of 5–10 T/s in the patient's examination area, in the work place located usually in a distance of at least 1 m from this area did not exceed 0.1 T/s. Worker's exposure is 200-fold lower than the value established as safe

for the patient (IEC), four times lower than the permissible value for occupational exposure used in Poland and should be also lower than ICNIRP occupational guidance for gradient fields (as the measurements technique used for presented investigations was different than recommended by ICNIRP's guidance, only rough comparison of presented results with ICNIRP's is justified).

In the case of open magnet, the higher level of workers' body exposure to time-varying fields is possible in direct proximity of patient's location, because nothing prevent the access of workers into the close proximity of patient's examination area between magnet legs.

5. DISCUSSION

Health care staff members could be exposed to high static magnetic field many times a day and during long working years. The epidemiological data concerning the health consequences of chronic exposure to strong static magnetic field are still very limited, because of relatively short duration of use of MRI technique and relatively small number of exposed workers [17]. Data presented in this paper describe in details variability of workers exposure from variety of MRI devices, what can support the need of data referring to the monitoring of occupational exposure from MRI mentioned by ICNIRP's statement on research needs for static magnetic fields [19]. Some recently coming results of biomedical investigations provoke questions if limitations based on ICNIRP'1994 are not too liberal in the case of chronic occupational exposure. It is the most important justification, that the regulations established in Poland contain more restrictive limitations of permissible worker's exposure than international recommendations and guidelines.

According to the regulations in force in Poland, as well as EC directive the area of strong magnetic field should be labelled around the magnet. The aim of these labelling is to remind workers about avoiding exposure during their work. It is a good working practice consistent with the ALARA principle, recommended for as long as there are questions about health effects of chronic exposure. Additional function of this labelling is

the prevention against hazards caused by flying metallic objects, because the threshold for this technical hazard ($B = 3$ mT) is the same as the limit of occupational exposure fixed in Poland (harmonised with general public permissible exposure in Poland).

Presented discussion shown that both assessment of worker's exposure level and duration should be consider with significant uncertainty of them. In the contrary the static magnetic field spatial distribution in the vicinity of the magnet's housing can be established relatively precise, with uncertainty of the order of magnetic flux meters calibration's uncertainty.

The majority of MRI devices can be a source of significant exposure level, worker's whole body and hands, and all devices can be a source of exposure excessive its permissible duration during a shift, in the case of improper work organisation (i.e., when the attendant is not keeping sufficient distance from the magnet or remains too long in the vicinity of it). It has been noticed that proper ergonomic conditions allow the considerably reduction of the exposure level and duration. Following the ergonomical data, it is possible to touch the device's housing from the distance of 0.6–0.7 m (distance of straight hand). So in the case of reasonable design of MRI devices when it is the possibility of its operation in the distance from the magnet no less than 0.5 m, all safety requirements mentioned in Table 1 could be in compliance during a routine MRI-operation. If that worker has to lean against magnet housing all the requirements mentioned in section 2 are exceeded. Similarly in the case of a plug-in point for a cable of diagnostic coils situated inside a magnet bore. Worker's exposure level from an open 0.2-T MRI device can be comparable to exposure from 1.5-T bore one. Similar observations concerning the possibility of very high exposure from relatively low level field produced by open MRI devices were reported also by COMAR paper [17].

6. CONCLUSION

Given the fact that MRI devices contain strong magnets, exposure of health care workers to static magnetic fields is significant. Fortunately during

patient's examination, health care workers are seldom exposed to a gradient fields. Gradient field exposure can occur if patient needs special attention during examination (e.g., claustrophobic individual, children, serious health condition), during the contrast injecting for dynamic contrast examination or in the case of any emergency problems.

In the situation that exposure assessment uncertainty seems to be even of order 50% or more, the exposure limits 100-, 200- and 500-mT should be taken for practical occupational health and safety engineering as similar level of worker's protection against excessive exposure, in the case of device producing so heterogeneous exposure, as exists in the vicinity of MRI magnets' housing.

Workers' health and safety training should present them methods for their exposure reduction during patient's attending. Medical staff should have also at disposal proper equipment for reducing the exposure, e.g., MRI table automatically pushed away from the magnet or undocked for patient's preparing before the examination, an optical positioning system for a fast and easy set up of the MRI table before inserting it into magnet.

Sufficient reduction of the workers exposure level is possible when requirement of the possibility of its operation in the distance from the magnet no less than 0.5 m was considered while designing of MRI device.

Further research advised by ICNIRP [19], including monitoring of occupational exposure, epidemiological studies of possible long-term health effects in staff with occupational exposure, particularly those with high levels of cumulative exposure and on biological effects of strong static magnetic fields, should solve questions for further decisions concerning the permissible exposure of workers to static magnetic field.

REFERENCES

1. Markisz J, Aquilia M. Technical magnetic resonance imaging. New York, NY, USA: Appleton & Lange; 1996.
2. Regulation of the Minister of Labour and Social Policy of 29 November 2002 on the maximum admissible concentrations and intensities for agents harmful to health in the working environment. Dz. U. 2002;217(item 1833):13614–60. In Polish. (First edition covering static magnetic field: Dz. U. 1995;69(item 351), revised in 2001).
3. Regulation of the Minister of Environment of 30 October 2003 on maximum admissible levels of electromagnetic fields in the environment and methods of checking compliance to these levels. Dz. U. 2003;192(item 1883):13006–12. In Polish.
4. Polish Standardisation Committee Polski Komitet Normalizacyjny (PKN). Labour protection in electromagnetic fields and radiation of the frequency range from 0 Hz to 300 GHz. Part 1: Terminology. Part 3. Methods of measurement and evaluation of the field on the work stands (Polish Standard No. PN-T-06580:2002). Warszawa, Poland: PKN; 2002. In Polish.
5. International Commission on Non-Ionizing Radiation Protection. Guidelines on limits of exposure to static magnetic. Health Phys. 1994;66(1):100–6.
6. Institute of Electrical and Electronics Engineers (IEEE). IEEE standard for safety levels with respect to human exposure to electromagnetic fields, 0–3 kHz (Standard No. C.95.6). New York, NY, USA: IEEE; 2002.
7. American Conference of Governmental and Industrial Hygienists (ACGIH). TLVs and BEIs. Based on the documentations for Threshold Limit Values for chemical substances and physical agents & Biological Exposure Indices. Cincinnati, OH, USA: ACGIH; 2005.
8. Directive 2004/40/EC of the European Parliament and of the Council of 29 April 2004 on the minimum health and safety requirements regarding the exposure of workers to the risks arising from physical agents (electromagnetic fields) (eighteenth individual Directive within the meaning of Article 16(1) of Directive 89/391/EEC). Official Journal of the European Union L 159, April 30, 2004. p. 1–26.
9. International Electrotechnical Commission (IEC). Medical electrical equipment. Part 2: Particular requirements for the safety of magnetic resonance equipment for medical diagnosis (Standard No. IEC-601-2-33:1995). Geneva, Switzerland: IEC; 1995

10. Karpowicz J, Gryz K. Static and gradient magnetic fields of MRI systems—methods of evaluating occupational exposure used in Poland. In: *Safety in health services—medical technology, radiation, electricity (ISSA Prevention Series 2043)*. Köln, Germany: International Social Security Association (ISSA); 2001. p. 118–21.
11. Korniewicz H, Gryz K, Karpowicz J. Method of measuring and evaluating occupational exposure to gradient magnetic fields of MRI systems. In: *Polish Academy of Sciences, XI National Science Conference Biocybernetics and Biomedical Engineering*, Warsaw, 1999. p. 368–72. Warszawa, Poland: Polska Akademia Nauk, Instytut Biocybernetyki i Inżynierii Biomedycznej. In Polish.
12. Reilly PJ. *Applied bioelectricity. From electrical stimulation to electropathology*, New York, NY, USA: Springer; 1998.
13. Jokela K. Restricting exposure to pulsed and broadband magnetic fields. *Health Phys.* 2000;79(4):373–88.
14. International Commission on Non-Ionizing Radiation Protection (ICNIRP). *Guidance on determining compliance of exposure to pulsed and complex non-sinusoidal wave below 100 kHz with ICNIRP guidelines*. *Health Phys.* 2003;44(4):494–522.
15. Polish Committee for Standardisation, Measurements and Quality Polski Komitet Normalizacji, Miar i Jakości. *Labour protection in magnetostatic field. Equipment and methods for measurements magnetostatic intensities (Polish Standard No. PN-90/T-06583:1990)*. Wydawnictwa Normalizacyjne ALFA; 1990. In Polish.
16. Centre for Testing and Measurement for Improvement of Safety of Products and Working Life. *Final report, January 2006 [unpublished report]*. Warszawa, Poland: Central Institute for Labour Protection – National Research Institute; 2006. In Polish.
17. International Organization for Standardization (ISO)/International Electrotechnical Commission (IEC). *Proficiency testing by interlaboratory comparison—part 1: development and operation of proficiency testing schemes (ISO/IEC Guide No. 43-1:1997)*. Geneva, Switzerland: ISO; 1997.
18. Bassen H, Schaefer DJ, Zaremba L, Bushberg J, Ziskin M, Foster KR. IEEE Committee on Man and Radiation (COMAR) *Technical Information Statement “Exposure of medical personnel to electromagnetic fields from open magnetic resonance imaging systems”*. *Health Phys.* 2005;89(6):684–9.
19. ICNIRP statement on medical magnetic resonance (MR) procedures: protection of patients. *Health Phys.* 2004;87(2):197–216.